







Yilmaz TK 503

Сварочный автомат
для производства ПВХ окон

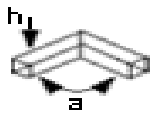
* номенклатура запасных частей

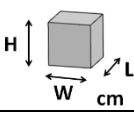
ТЕХНИЧЕСКИЕ ОСОБЕННОСТИ

							
				cm	kg	kg	
TK 503	1.5 Kw 50 Hz. 230 V AC P N PE	h = 130mm max. a = 30 ° - 180 °	6/8 Bar	20 Lt. / dak. Lt/min	W = 70 L = 59 H = 74	115	128

РАЗМЕРЫ



РИСУНОК 1



РИСУНОК 3

ПЕРЕЧЕНЬ ДЕТАЛЕЙ

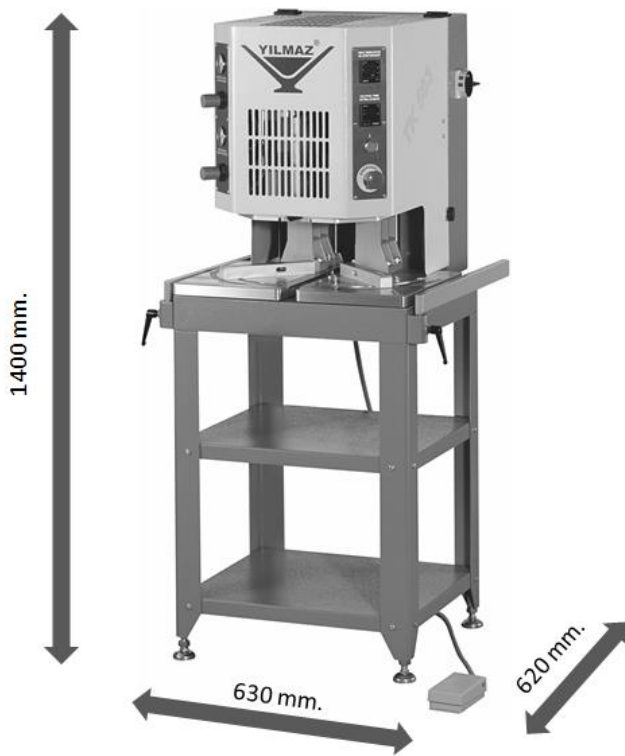

РИСУНОК 2

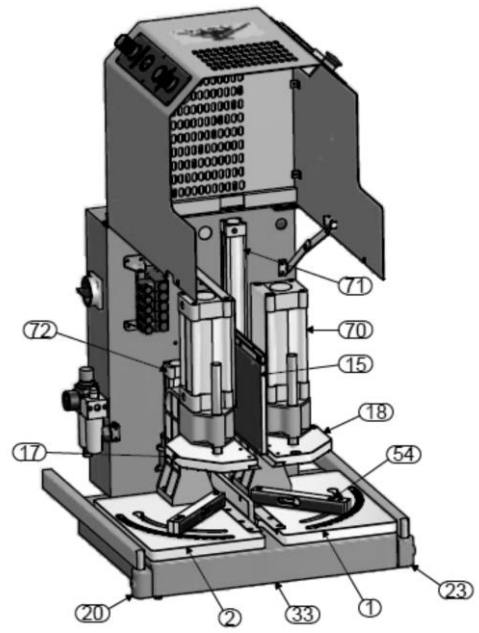

РИСУНОК 4

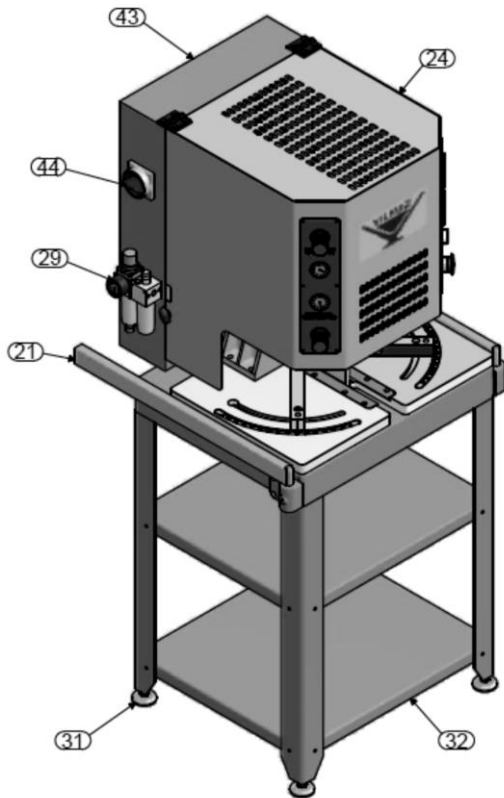
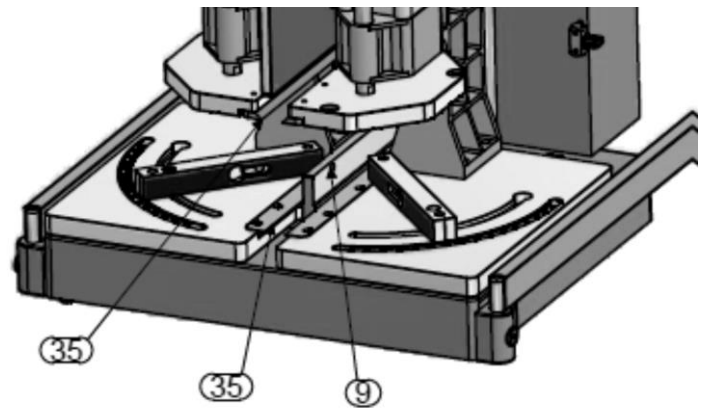

РИСУНОК 5

№	КОД / артикул	КОЛИЧЕСТВО	№	КОД / артикул	КОЛИЧЕСТВО
1	2TU012410-0057	1	70	1PN020000-0040	2
2	2TU012410-0058	1	71	1PN020000-0108	1
9	2TU011210-0409	1	72	1PN020000-0109	1
15	3UA610010-0001	1			
17	2TU012410-0060	1			
18	2TU012410-0059	1			
20	2TU012510-0279	1			
21	2TU011310-0001	2			
23	2TU012510-0278	1			
24	1SA030000-0052	1			
29	3UA110030-0020	1			
31	1SC170000-0007	4			
32	1SA050000-0162	1			
33	2TU012510-0323	1			
35	2TU011210-0169	4			
43	1SA020000-0028	1			
54	2TU012210-0498	2			